

mentemano

Indice / Index

Caleido	Pag. 1
Grimilde	Pag. 3
Zefiro	Pag. 5
Bosco	Pag. 7
Dieci Dieci	Pag. 9
Dorian	Pag. 11
Tubolar	Pag. 13
Corbel	Pag. 15
X-marble	Pag. 17
Keplero	Pag. 19
Less	Pag. 21
More	Pag. 23
Less cassetti / drawers	Pag. 25
Spider	Pag. 27

mentemano

Mentemano è un nome che conduce a una riflessione: è la mente che guida la mano per realizzare un arredo o è la funzione, la mano, che fornisce lo stimolo alla mente per concepire un progetto?

Nei prodotti disegnati da Nicola Gisonda; materia, funzione e spazio sono sempre protagonisti di una visione tipicamente architettuale che conferisce alla collezione, un'identità ed un design del tutto singolare.

Mentemano is a concept leading to a consideration: is the "mente" (mind) which leads the "mano" (hand) to create a piece of furniture or is it the opposite, having the mind as source of inspiration to conceive the project?

All the products made by Nicola Gisonda are influenced by a unique architectural perception and based on attention to materials, functionality and space.

Caleido

Nicola Gisonda
2019

Un insieme di curve definisce una struttura in tondino di metallo piegato, a formare tre doppie gambe.

Il piano d'appoggio di forma circolare è realizzato in legno laccato ed arricchito da stampe digitali. Il progetto rimanda ai riflessi multipli visibili all'interno di un caleidoscopio, formando immagini spesso simmetriche che mutano in modo imprevedibile ad ogni movimento.

A bended steel structure of curves with three double legs.

The circular stand top is made of lacquered wood and enriched with digital prints. The project takes inspiration from the movement of symmetrical images inside kaleidoscopes.



Grimilde

Nicola Gisonda
2019

Console desk versatile dalle linee chiare e minimali, definita da una base in tondino di metallo piegato verniciato e piani in legno laccato. I due sottopiani sono arricchiti da stampe digitali a disegno geometrico. Grimilde si completa di alzata portaoggetti che accoglie uno specchio. Se rimosso, diventa ideale scrittoio, altrimenti una perfetta postazione make-up.

Console desk made of bended coated steel defined by clear and minimal lines with lacquered wood shelves. The two underneath shelves are enriched with digital prints. The upper shelf is furnished with a round mirror offering a perfect make-up station but also a writing desk depending on your choice.

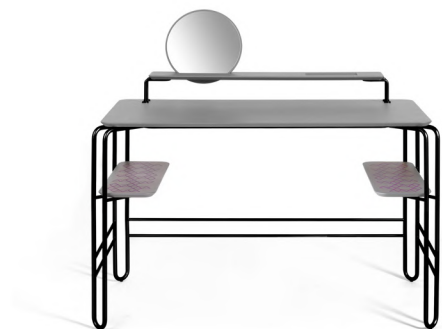
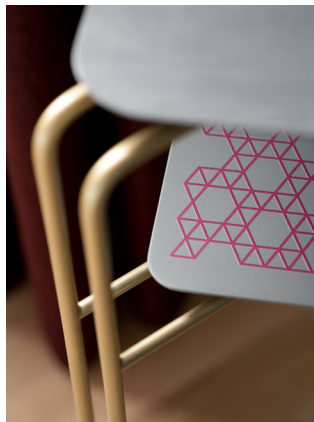

Zefiro

Nicola Gisonda
2019

Tre differenti pannelli compongono il paravento.

Le cerniere permettono alla struttura di assumere svariate forme. I pannelli sono laccati e si caratterizzano per le loro stampe digitali, conferendo così movimento e leggerezza all'intera struttura.

Ispiratore è il mondo della vela; gli elementi laterali e i pannelli rievocano le vele di una regata che si intrecciano all'orizzonte.

The screen is composed by three different panels.

The hinges allow the structure to take different shapes. The lacquered panels are enriched with digital prints giving movement and lightness to the whole structure.

Zefiro takes inspiration from sailing; the side elements and the panels are all related to the image of sails on the horizon during a sailing race.

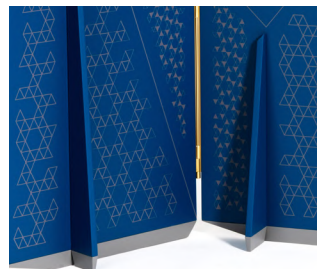

Bosco

Nicola Gisonda
2019

La scenario di un bosco e i suoi elementi verticali e diagonali, a intrecciarsi, come fonte d'ispirazione.

Libreria costituita da profili metallici verniciati con cinque ripiani in CDF naturale, tutti diversi tra loro.

Un complemento d'arredo dinamico, distante dai canoni più classici per una ricerca di stile unica ed innovativa.

Bosco takes inspiration from a forest scenario and the intersection of nature and wood elements.

A bookcase composed of coated metal profiles with five natural CDF shelves made in different shapes.

A dynamic piece of furniture, far away from the classical standards in order to reach a unique and innovative style.



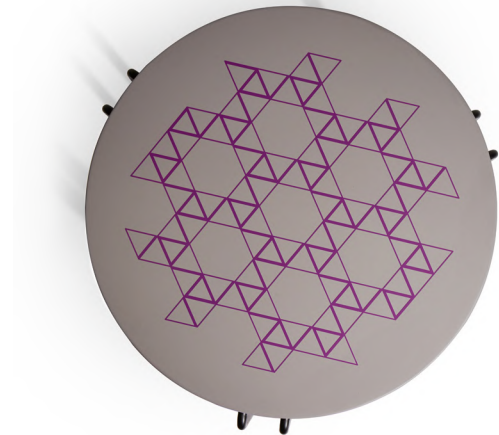
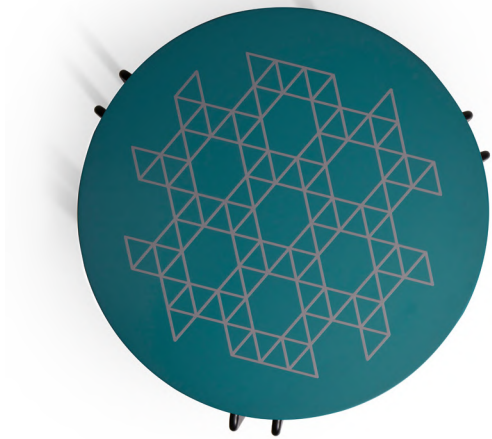
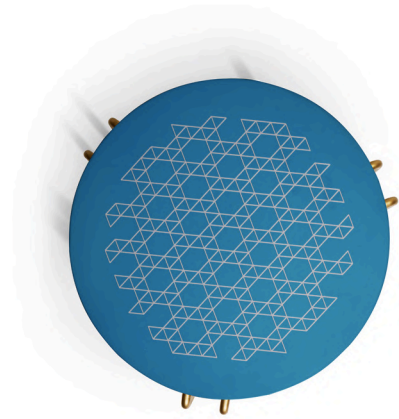
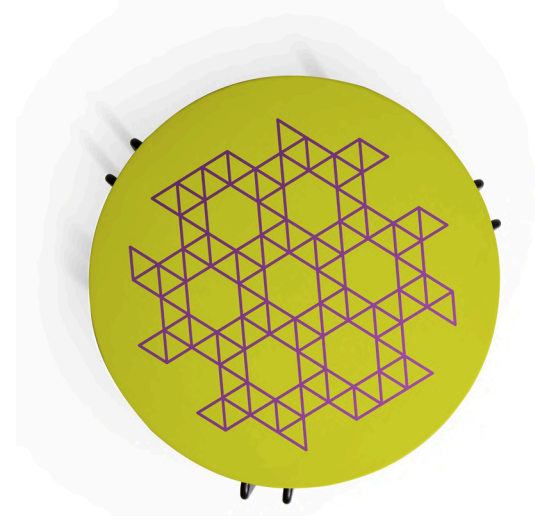
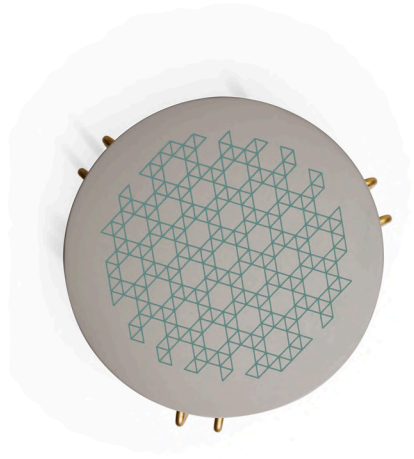

Il focus sui dettagli e sulle finiture diventa elemento essenziale nel processo creativo del designer.

Si realizzano prodotti che dialogano tra loro, definendo l'ambiente con le loro forme e linee.

Arredi dal carattere forte che si distolgono dalle tendenze del momento; frutto di una ricerca continua, volta alla sperimentazione e all'indagine di una cifra stilistica elegante, sobria e di personalità.

The focus on details and finishing becomes the essential element during the whole creative process.

The products, through their shapes and lines, create a dialogue between themselves and the space all around.

Strong character pieces of furniture, far away from the trends of the moment and based on a personal ongoing design research, looking for elegance, sobriety and personality.

Dieci Dieci

Nicola Gisonda
2019

Set di appendini con struttura in profilo pieno a spigolo vivo, composto da tre elementi aventi dimensioni e forme diverse.
Linee a formare angoli retti, in perfetto connubio con la sezione quadrata del profilo. Installazione a proprio piacimento.

*Set of hangers based on a full profile structure composed by three elements with different shapes.
The lines create right angles as a perfect match with the square section of the profile.
Arrangement of the set on your own preference.*

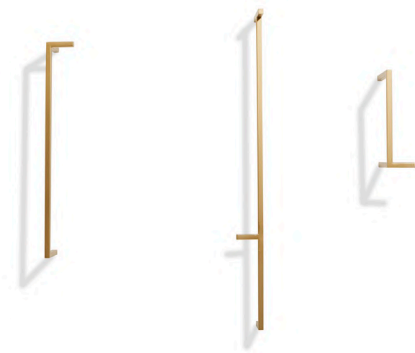

Dorian

Nicola Gisonda
2019

Uno specchio di forma quadrata dagli angoli stondati.
La sezione della cornice disegna una forma conica di pronunciato spessore. Interamente realizzato in legno laccato. Disponibile in nero opaco.

*Square shape mirror with rounded angles.
The frame reminds of a conic section.
Fully made of lacquered wood. Available in matt black.*



Tubolar

Nicola Gisonda
2019

La base in tubolare di metallo verniciato, ricrea un intreccio di linee marcate e dal disegno speculare. Il piano in cristallo temperato fumè dona eleganza e permette di intravedere la struttura portante del tavolo.
Due le forme disponibili: ovale e rettangolare.

The metal tubular coated base forms a marked intersection of lines. The smoked tempered glass gives elegance and makes the supporting structure visible.

Two available shapes: oval and rectangular.



Corbel

Nicola Gisonda
2019

La mensola si compone di due cristalli accoppiati. Il materiale diventa qui protagonista, dando vita ad innumerevoli riflessi di luce in tutte le direzioni. Gli elementi divisorii di Corbel permettono di contenere ed ordinare oggetti e libri.

*This shelf is composed by two paired tempered glasses. The use of this material is the key point of the project, having light reflection spreading all over the place.
The dividing elements make the piece a perfect container for objects and books.*



X-marble

Nicola Gisonda
2019

Il tavolino è composto da una base a forma di X che fuoriesce dal piano.
Gli elementi sono disposti a formare idealmente un incastro di lastre; il disegno è rimarcato attraverso le teste delle stesse.

*The coffee table has an X shape base partly coming out from the surface.
The elements form an intersection of slabs making a focus on the unique design of the piece through their extremities.*



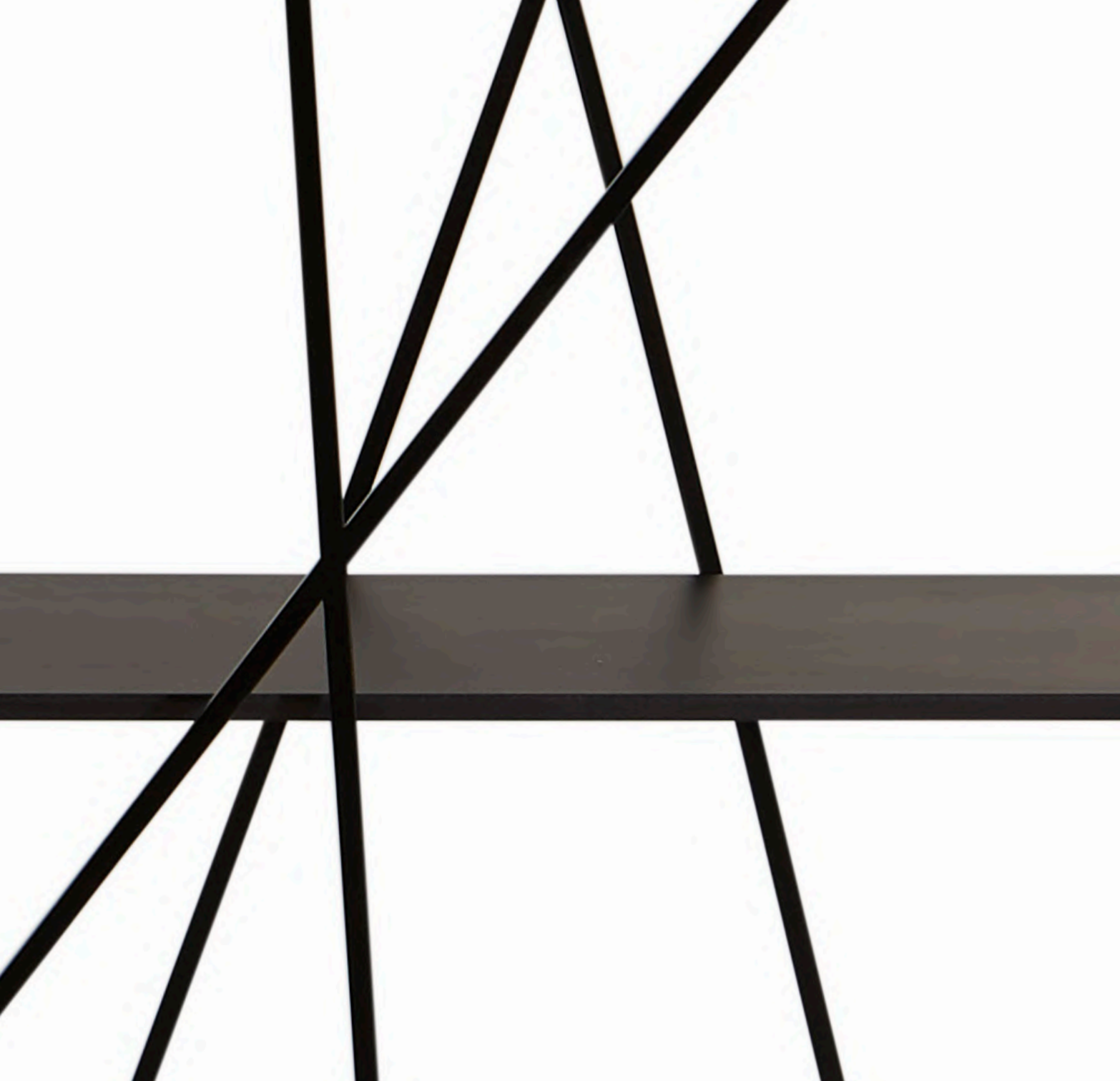

mentemano

L'intera collezione è realizzata in Italia, affidandosi alle maestranze artigianali ed industriali del territorio lombardo.

Elevata qualità dei prodotti, un gusto tipicamente made in Italy e durabilità nel tempo, sono i punti di forza dei complementi d'arredo firmati Mentemano.

The collection is fully made in Italy, working with local artisans from Lombardy region. High quality, Italian craftsmanship and lifetime allure are the key points of Mentemano.

Keplero

Nicola Gisonda
2020

Come un pianeta ed un satellite che gli ruota idealmente attorno, il tavolino presenta due piani di diverse dimensioni, in parte fresati, a formare due vassoi portaoggetti che rimandano ad altri due "satelliti". La base in metallo verniciato, è costituita da sottili elementi che si intersecano a formare un disegno geometrico leggero, diverso a seconda di come lo si guarda.

La colorazione è sempre unica, la stessa per gambe e piani, in modo da donare continuità agli elementi.

Such as a planet and a satellite which ideally turns around it, Keplero is composed by two storage trays reminding of two other "satellites". The metal coated base has a structure made of thin intersected elements to create a light design, giving a unique perception according to the different points of view.

Just one palette available in order to give continuity to the whole structure.



Less

Nicola Gisonda
2020

Il design si sviluppa tramite un processo di sottrazione; dall'involucro immaginato della madia si sottrae infatti materiale, sino a giungere al suo scheletro. La struttura della madia è in legno massello e definita da elementi lineari, arrotondati sulle estremità in corrispondenza dei nodi di congiunzione.

La poetica "Less is more" di Mies van der Rohe diventa concept d'ispirazione per il progetto, attraverso un processo creativo che persegue la semplicità.

Due le versioni ideate: una aperta con la possibilità di accessori (contenitori More); una chiusa con due cassetti.

The design comes from a subtraction process in order to make a focus on the basic frame of Less. The whole structure is made of solid wood and based on clean lines which are rounded on the extremities.

The poetics "Less is more" of Mies van der Rohe becomes the inspiring concept for the project, through creative steps having ease as final goal.

Two available versions: open with accessories as feature (More). Close with two drawers.



More

Nicola Gisonda
2020

Contenitori di complemento a Less.
Un vassoio e due scatole in due dimensioni con
coperchio annesso, realizzati in legno con la
possibilità di inserti argentati bronzo.

*Complementary containers for Less.
A tray and two boxes available in two dimensions
with cover, made of wood with bronze mirror
inserts as possible option.*

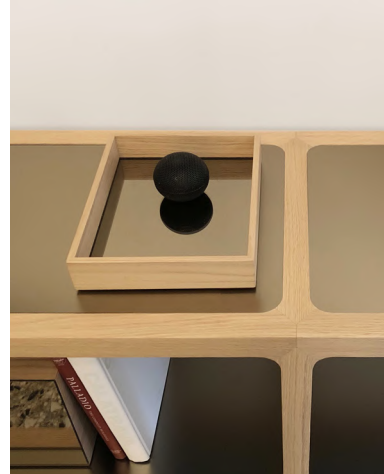

Less cassetti / drawers

Nicola Gisonda
2020

Anche in Less cassetti ritroviamo la poetica di Mies van der Rohe.

La struttura della madia interamente in legno massello è definita da elementi lineari, arrotondati sulle estremità in corrispondenza dei nodi di congiunzione, rimanendo comunque ben delineata e facilmente leggibile.

La versione si arricchisce con due ampi cassetti.

Also Less drawers is influenced by Mies van der Rohe's poetics.

Made of solid wood with a frame based on clean lines rounded on the extremities, Less drawers remains well-defined.

This version is enriched with two wide drawers.



Spider

Nicola Gisonda
2020

Il progetto si caratterizza per la marcata leggerezza e la ricerca del dettaglio, creando molteplici suggestioni. Volumi e geometrie, sono il risultato di un processo tecnico ed estetico che ricerca un'eleganza autentica.

L'attenzione al particolare invece, si ritrova nell'angolo arrotondato delle gambe e del piano di Spider. Questa singolarità viene esaltata quando piano e gambe si incontrano.

La loro unione rimanda ad un giunto all'apparenza instabile; la suggestione è quella di vedere il tavolo fluttuare.

The project is based on lightness and attention to details. Volumes and lines are the result of a technical and aesthetic process in order to reach a real elegance.

The rounded angles of the legs and the top are the main details of Spider.

This feature makes the table apparently unstable giving a sense of fluctuation.



Indice / index

Caleido	Pag. 29, 43
Grimilde	Pag. 30, 43
Zefiro	Pag. 31, 44
Bosco	Pag. 32, 44
Dieci Dieci	Pag. 33, 44
Dorian	Pag. 34, 44
Tubolar	Pag. 35, 44
Corbel	Pag. 36, 45
X-marble	Pag. 37, 45
Keplero	Pag. 38, 45
Less	Pag. 39, 45
More	Pag. 40, 46
Less cassette / drawers	Pag. 41, 46
Spider	Pag. 42, 46

Caleido

Dimensioni

42 x 47 cm
35 x 41 cm

Materiali - Finiture

Base: metallo verniciato a polvere opaco
Piano: Mdf laccato opaco con stampa digitale

Colori

Base: ottone, nero

Piano: verde petrolio
Stampa: grigio

Piano: lime
Stampa: viola

Piano: grigio
Stampa: viola

Piano: blu ottanio
Stampa: grigio

Piano: grigio
Stampa: verde petrolio

Dimensions

42 x 47 cm
35 x 41 cm

Materials - Finishes

Base: powder coated matt metal
Top: matt lacquered
Mdf with digital print

Colors

Base: brass, black

Top: petrol green
Printing: grey

Top: lime
Printing: purple

Top: grey
Printing: purple

Top: teal blue
Printing: grey

Top: grey
Printing: petrol green

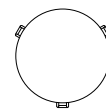
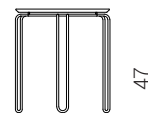

42

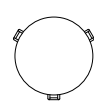
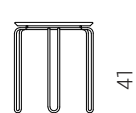

35

29 . 30

Grimilde

Dimensioni

120 x 65 x 88 cm
con specchio h 114 cm

Materiali - Finiture

Base: metallo verniciato a polvere opaco
Piani: Mdf laccato opaco con stampa digitale

Colori

Base: ottone, nero

Piani: verde petrolio
Stampa: grigio

Piani: blu ottanio
Stampa: grigio

Piani: grigio
Stampa: viola

Dimensions:

120 x 65 x 88 cm
with mirror h 114 cm

Materials - Finishes

Base: powder coated
matt metal

Shelves: matt lacquered
Mdf with digital print

Colors

Base: brass, black

Shelves: petrol green
Printing: grey

Shelves: teal blue
Printing: grey

Shelves: grey
Printing: purple

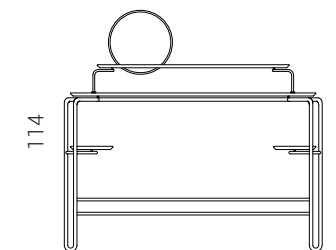

114

88

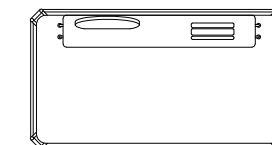

120

65

Zefiro

31 . 32

Dimensioni:

196 x 28 x 181,5 cm

Materiali - Finiture

Pannelli: Mdf laccato opaco con stampa digitale
Cerniere: metallo verniciato a polvere opaco

Colori

Pannelli: verde petrolio
Stampa: grigio
Cerniere: ottone, nero

Pannelli: blu ottanio
Stampa: grigio
Cerniere: ottone, nero

Dimensions

196 x 28 x 181,5 cm

Materials - Finishes

Panels: matt lacquered Mdf with digital print
Hinges: powder coated matt metal

Colors

Panels: petrol green
Printing: grey
Hinges: brass, black

Panels: teal blue
Printing: grey
Hinges: brass, black

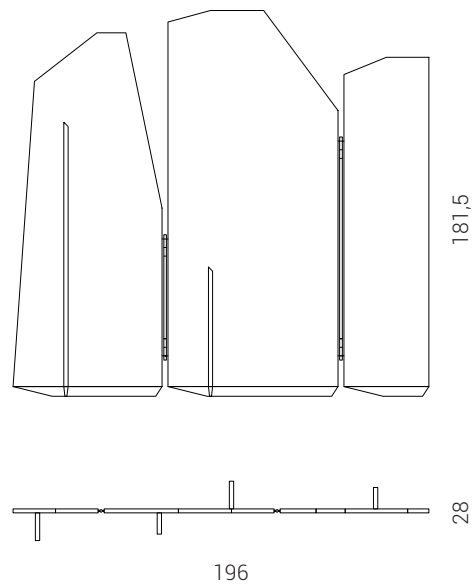

Bosco

Dimensioni

116 x 42 x 190,5 cm

Materiali - Finiture

Struttura: metallo verniciato a polvere opaco
Piani: CDF naturale opaco

Colori

Struttura: nero
Piani: CDF naturale

Dimensions

116 x 42 x 190,5 cm

Materials - Finishes

Structure: powder coated matt metal

Shelves: natural matt CDF

Colors

Structure: black
Shelves: natural CDF

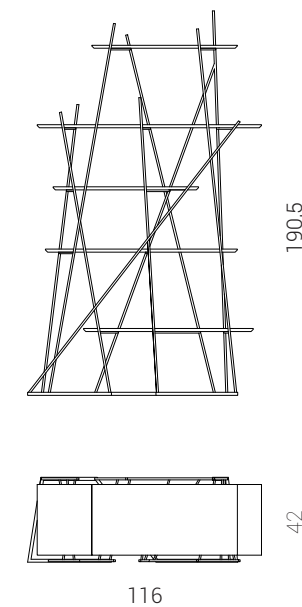

Dieci Dieci

Dimensioni

10 x 5 x 60 cm
9 x 5 x 40 cm
12,5 x 5 x 18 cm

Materiali - Finiture

Metallo verniciato a
polvere opaco

Colori

Ottone, nero

Dimensions

10 x 5 x 60 cm
9 x 5 x 40 cm
12,5 x 5 x 18 cm

Materials - Finishes

Powder coated matt
metal

Colors

Brass, Black

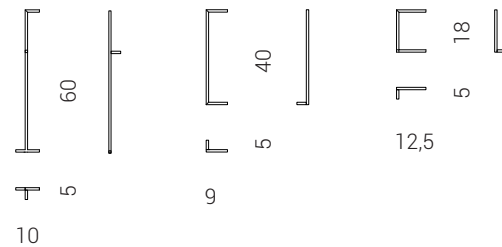

33 . 34

Dorian

Dimensioni

80 x 5 x 80 cm
54 x 5 x 54 cm

Materiali - Finiture

Cornice: Mdf laccato
opaco
Specchio: vetro
riflettente extrachiaro
argentato

Colori

Nero

Dimensions

80 x 5 x 80 cm
54 x 5 x 54 cm

Materials - Finishes

Frame: lacquered matt
Mdf
Mirror: extra clear
reflecting
silver-finished glass.

Colors

Black

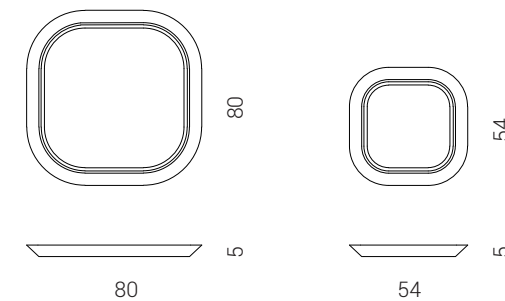

Tubolar

35 . 36

Dimensioni

200 x 100 x 75 cm
220 x 100 x 75 cm

Materiali - Finiture

Base: metallo
verniciato a polvere
opaco
Piano: cristallo
temperato a filo lucido
- elisse, rettangolare

Colori

Base: ottone, nero
Piano: grigio fumè

Dimensions

200 x 100 x 75 cm
220 x 100 x 75 cm

Materials - Finishes

Base: powder coated
matt metal

Top: polished edge
tempered glass - ellipse,
rectangular

Colors

Base: brass, black
Top: smoked grey

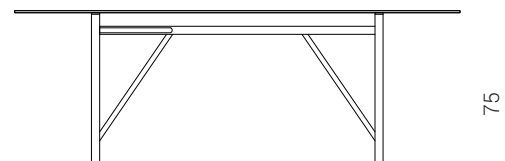

75

rettangolare/rectangular

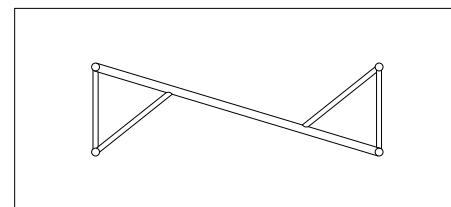

100

200 / 220

elisse/ellipse

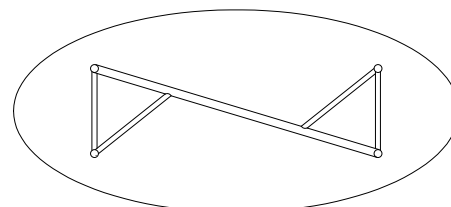

100

200 / 220

Corbel

Dimensioni

145 x 27 x 28 cm

Materiali - Finiture

Vetro riflettente
accoppiato bifacciale

Colori

Grigio fumè

Materiali - Finiture

Cristallo lacobel
accoppiato bifacciale

Colori

Standard: bianco
satinato e nero
satinato
Su richiesta: colori RAL

Dimensions

145 x 27 x 28 cm

Materials - Finishes

Double-sided sandwich
reflecting glass

Colors

Smoked grey

Materials - Finishes

Lacobel double-sided
sandwich glass

Colors

Standard: satin white
and satin black

On request: RAL colors

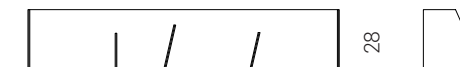

28

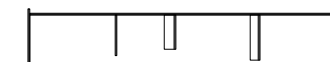

27

145

X-marble

37 . 38

Dimensione

95 x 60 x 39 cm
h max 47 cm

Dimensions

95 x 60 x 39 cm
h max 47 cm

Materiali - Finiture

Marmo levigato

Materials - Finishes

Polished marble

Colori:

Marmo di Carrara

Colors:

Carrara marble

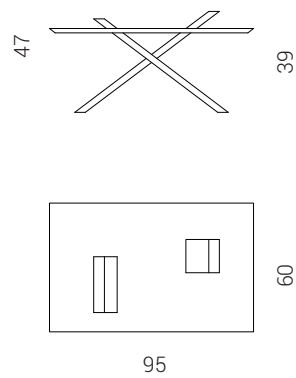

Keplero

Dimensioni

95 x 70 x 31/39 cm

Dimensions

95 x 70 x 31/39 cm

Materiali - Finiture

Base: metallo
verniciato a polvere
opaco
Piani: MDF laccato
opaco

Materials - Finishes

Base: powder coated
matt metal

Tops: matt lacquered
MDF

Colori

Colori RAL
Unico colore per
struttura e piani

Colors

RAL colors
One color for structure
and tops

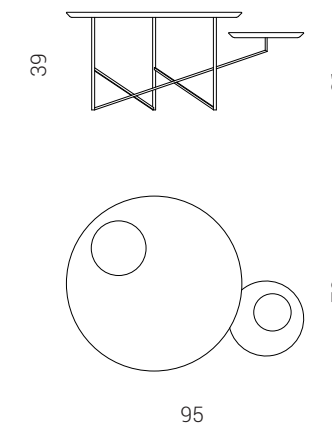

Less

39 . 40

Dimensioni

200 x 44 x 72 cm

Materiali - Finiture

Struttura: legno massello
Piani: Mdf impiallacciato o vetro

Colori

Struttura: Rovere naturale o Noce Canaletto, finito con trasparente

Piani: Rovere naturale o Noce Canaletto, finiti con trasparente

Piani: vetro argentato
bronzo satinato

Dimensions

200 x 44 x 72 cm

Materials - Finishes

Structure: solid wood

Tops: veneered Mdf or glass

Colors

Structure: natural Oak or Walnut Canaletto, transparent finished

Tops: natural Oak or Walnut Canaletto, transparent finished

Tops: silver satin bronze glass

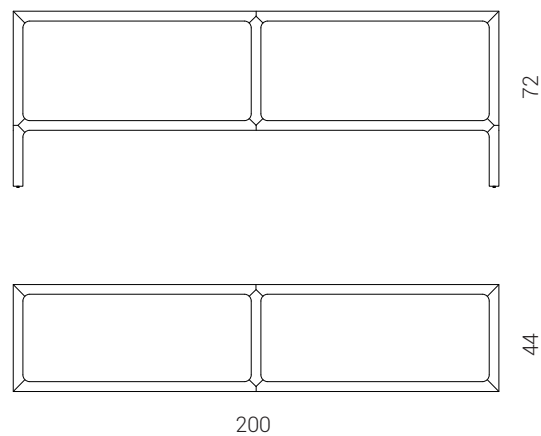

More

Tipo Dimensioni

- A** 23 x 28 x 5 cm
- B** 20 x 28 x 15 cm
- C** 25 x 28 x 25 cm

Materiali - Finiture
Mdf impiallacciato finito con trasparente

Colori

A-B-C Rovere naturale o Noce Canaletto

Materiali - Finiture
Mdf impiallacciato finito con trasparente e vetro

Colori

A-C Rovere naturale o Noce Canaletto con inserto in vetro riflettente argentato bronzo

B Rovere naturale o Noce Canaletto e inserto vetro argentato bronzo satinato

Type Dimensions

- A** 23 x 28 x 5 cm
- B** 20 x 28 x 15 cm
- C** 25 x 28 x 25 cm

Materials - Finishes
Transparent finished veneered Mdf

Colors

A-B-C Natural Oak or Walnut Canaletto

Materials
Transparent finished veneered Mdf and glass

Colors

A-C Natural Oak or Walnut Canaletto with silver bronze reflecting glass insert

B Natural Oak or Walnut Canaletto with silver satin bronze glass insert

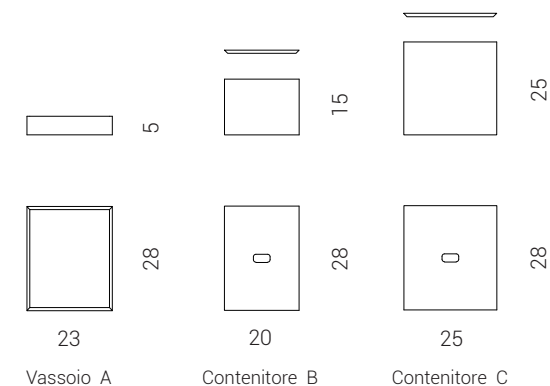

Less cassetti / drawers

41 . 42

Dimensioni

200 x 44 x 72 cm

Materiali - Finiture

Struttura: legno massello
Piano, frontale e laterale: Mdf impiallacciato
Cassetti: legno nobilitato

Colori

Struttura: Rovere naturale finito con trasparente
Piano, frontale e laterale: Rovere naturale finito con trasparente
Cassetti: grigio medio opaco

Struttura: Noce Canaletto finito con trasparente
Piano, frontale e laterale: Noce Canaletto finito con trasparente
Cassetti: grigio medio opaco

Dimensions

200 x 44 x 72 cm

Materials - Finishes

Structure: solid wood
Top, front and side: veneered Mdf
Drawers: ennobled wood

Colors

Structure: transparent finished natural Oak
Top, front and side: transparent finished natural Oak
Drawers: matt medium grey

Structure: transparent finished Walnut Canaletto
Top, front and side: transparent finished Walnut Canaletto

Drawers: matt medium grey

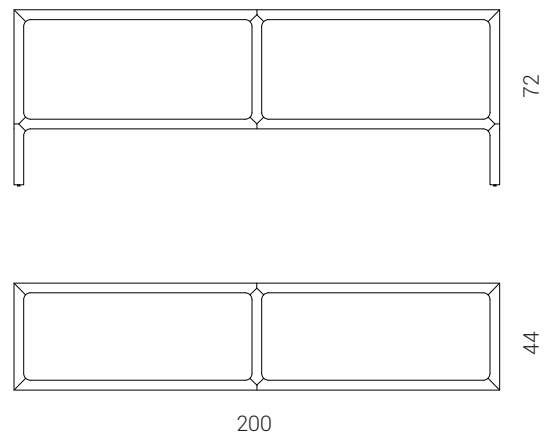

Spider

Dimensioni

220 x 100 x 75 cm

Materiali - Finiture

Mdf impiallacciato con sottostruttura in metallo

Colori

Tay tinto grigio finito con trasparente

Rovere rigatino naturale finito con trasparente

Noce Canaletto fiammato finito con trasparente

Dimensions

220 x 100 x 75 cm

Materials - Finishes

Veneered Mdf with metal substructure

Colors

Transparent finished grey Tay dyed

Transparent finished natural striped Oak

Transparent finished flamed Walnut Canaletto

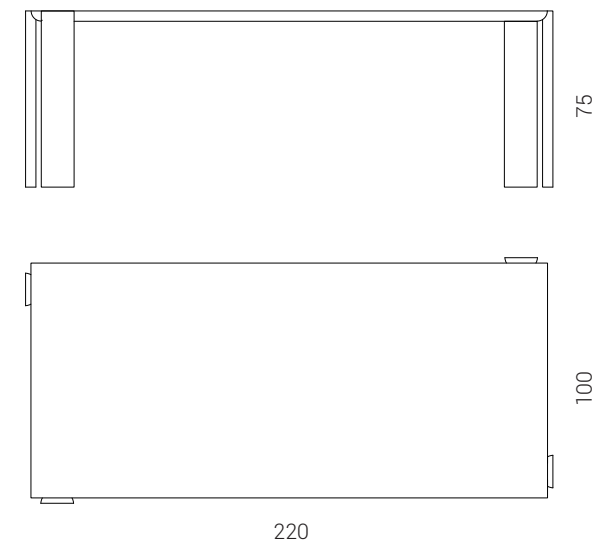

Finiture / Finishes

43 . 44

Caleido

Base
Base:



Nero opaco
Matt black



Ottone opaco
Matt brass

Piano
Top:



Lime e viola
Lime and purple



Grigio e viola
Grey and purple



Verde petrolio e grigio
Petrol green and grey



Blu ottanio e grigio
Teal blue and grey



Grigio e verde petrolio
Grey and petrol green

Grimilde

Base
Base:



Nero opaco
Matt black



Ottone opaco
Matt brass

Piani
Tops:



Verde petrolio e grigio
Petrol green and grey



Blu ottanio e grigio
Teal blue and grey



Grigio e viola
Grey and purple

Zefiro

Cerniere
Hinges:



Nero opaco
Matt black



Ottone opaco
Matt brass

Pannelli
Panels:



Verde petrolio e grigio
Petrol green and grey



Blu ottanio e grigio
Teal blue and grey

Bosco

Struttura
Structure:



Nero opaco
Matt black

Piani
Shelves:

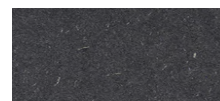

CDF nero naturale
Natural black CDF

Dieci Dieci

Struttura
Structure:



Nero opaco
Matt black



Ottone opaco
Matt brass

Dorian

Cornice
Frame:



Nero opaco
Matt black

Tubolar

Base
Base:



Nero opaco
Matt black



Ottone opaco
Matt brass

Piano
Top:



Grigio fumè
Smoked grey

Corbel

Struttura
Structure:



Lacobel bianco satinato
Satin white Lacobel



Lacobel nero satinato
Satin black Lacobel



Riflettente grigio fumè
Reflecting smoked grey

Su richiesta: colori RAL
On request: RAL colors

X-marble

Base e piano
Base and top:

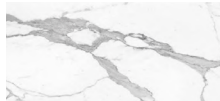

Marmo di Carrara
Carrara marble

Keplero

Base e piani
Base and tops:

Colori RAL
RAL Colors

Less

45 . 46

Struttura
Structure:



Noce Canaletto
Walnut Canaletto



Rovere naturale
Natural Oak

Piano
Top:



Noce Canaletto
Walnut Canaletto



Rovere naturale
Natural Oak

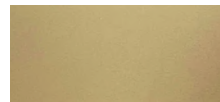

Argentato bronzo satinato
Silver satin bronze

More

Struttura
Structure:



Noce Canaletto
Walnut Canaletto

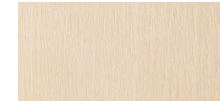

Rovere naturale
Natural Oak

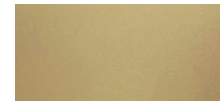

Argentato bronzo satinato
Silver satin bronze



Riflettente argentato bronzo
Reflecting silver bronze

Less (cassetti / drawers)

Struttura
Structure:

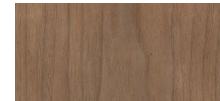

Noce Canaletto
Walnut Canaletto



Rovere naturale
Natural Oak

Spider

Base e piano
Base and top:



Noce Canaletto
Walnut Canaletto



Rovere naturale
Natural Oak

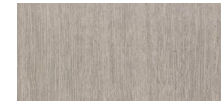

Tay tinto grigio
Grey Tay dyed

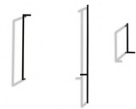

mentemano

via Mecenate 76
20138 Milano, Italy
t +39 02 58018669
info@mentemano.it
www.mentemano.it
@mentemano